

**Dimensions**

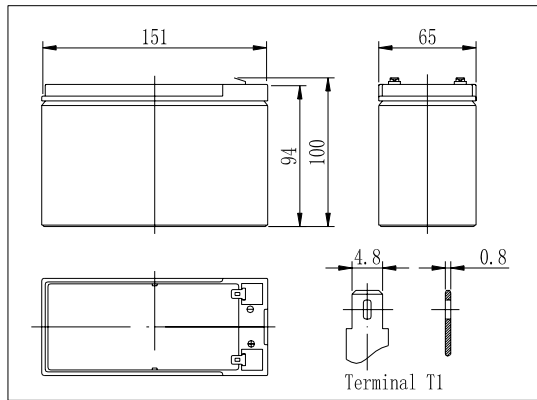

**Specifications**

Nominal Voltage	12 V	
Capacity(20HR, 25°C)	9 Ah	
Dimension	Length	151mm (5.94inch)
	Width	65mm (2.56inch)
	Height	94mm (3.70inch)
	Total Height	100mm (3.94inch)
Approx. Weight	2.6kg (5.73lbs)	
Internal resistance (Fully charged, 25°C)	Approx. 19mΩ	
Capacity affected by temperature (20HR)	40°C	102%
	25°C	100%
	0°C	85%
	-15°C	65%
Self-discharge (25°C)	3 month	Remaining Capacity: 91%
	6 month	Remaining Capacity: 82%
	12 month	Remaining Capacity: 65%
Nominal operating temperature	25°C ± 3°C (77°F ± 5°F)	
Operating temperature range	-15°C ~ 50°C (5°F ~ 122°F)	
Float charging voltage(25°C)	13.60 to 13.80V	
Cyclic charging voltage(25°C)	14.50 to 14.90V	
Maximum charging current	2.7A	
Terminal material	Copper	
Maximum discharge current	135A(5 sec.)	

- ◆ Absorbent glass mat technology;
- ◆ Recognized by UL & CE;
- ◆ ABS container.

**Charging Characteristics(25°C)**

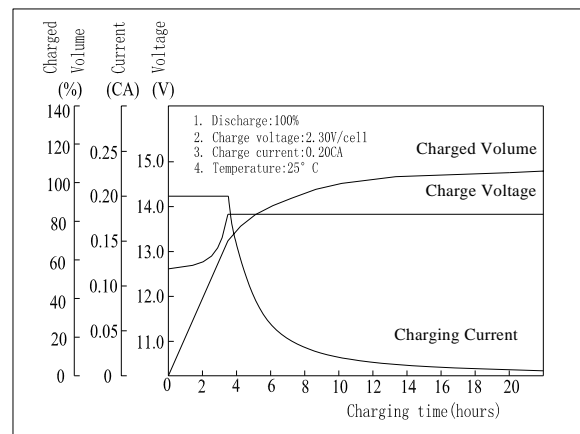

**Cycle Life(25°C)**

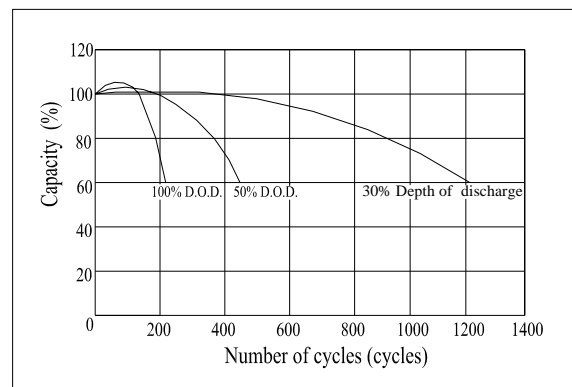

Note: Floating life at 20°C designed for 5 years.

**Constant Current Discharge Characteristics (A, 25°C)**

F.V/TIME	5min	10min	15min	30min	60min	3h	5h	10h	20h
9.60V	39.0	25.7	19.0	10.6	5.80	2.18	1.51	0.81	0.45
10.2V	37.1	24.2	18.1	10.2	5.57	2.15	1.49	0.81	0.45
10.8V	34.8	23.0	17.3	9.7	5.29	2.11	1.46	0.80	0.44

**Constant Power Discharge Characteristics (Watt, 25°C)**

F.V/TIME	5min	10min	15min	30min	60min	3h	5h	10h	20h
9.60V	435	290	217	121	67.2	25.9	18.0	9.72	5.40
10.2V	414	273	206	117	64.5	25.5	17.8	9.72	5.40
10.8V	388	259	197	111	61.3	25.1	17.4	9.60	5.28