

◆ **Dimensions**

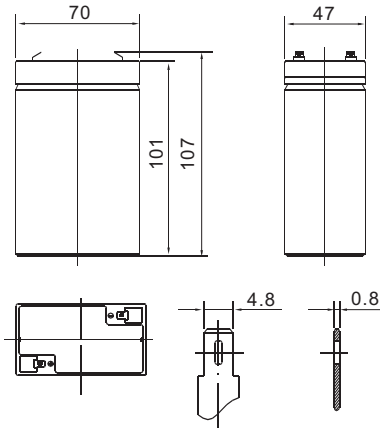

◆ **Specifications**

Nominal voltage		6 V
Capacity(20HR, 25°C)		4 Ah
Dimension	Length	70mm (2.76inch)
	Width	47mm (1.85inch)
	Height	101mm (3.98inch)
	Total height	107mm (4.21inch)
Approx. weight		0.75kg (1.65lbs)
Internal resistance (Fully charged, 25°C)		Approx. 25mΩ
Capacity affected by temperature (20HR)	40°C	102%
	25°C	100%
	0°C	85%
	-15°C	65%
Self-discharge (25°C)	3 month	Remaining capacity: 91%
	6 month	Remaining capacity: 82%
	12 month	Remaining capacity: 65%
Normal operating temperature		25°C ±3°C(77°F ±5°F)
Operating temperature range		-15°C ~50°C (5°F ~122°F)
Float charging voltage(25°C)		6.69 to 6.90V
Cyclic charging voltage(25°C)		7.20 to 7.50V
Maximum charging current		1.6A
Terminal material		Copper
Maximum discharge current		60A(5 sec.)

- ◆ Absorbent glass mat technology;
- ◆ Recognized by UL & CE;
- ◆ Flame retardant ABS container (UL94V-0/ 94V-2).

◆ **Charging Characteristics(25°C)**

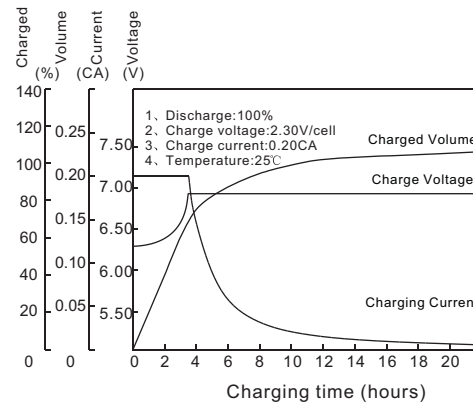

◆ **Cycle Life(25°C)**

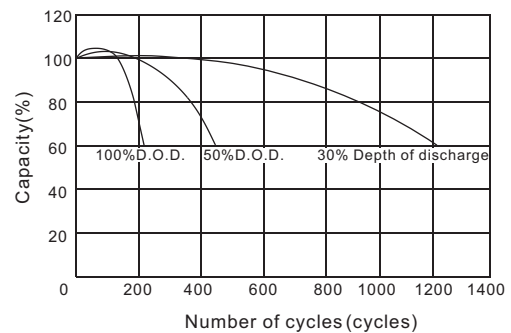

◆ **Note: Floating life designed for 5 years at 20°C.**

Constant Current Discharge Characteristics(A,25°C)

F.V./TIME	5min	10min	15min	30min	60min	3h	5h	10h	20h
4.80V	14.4	9.20	7.82	4.30	2.64	0.97	0.69	0.38	0.20
5.10V	13.7	8.74	7.51	4.13	2.53	0.96	0.68	0.38	0.20
5.40V	12.9	8.22	7.13	3.92	2.40	0.94	0.67	0.37	0.20

Constant Power Discharge Characteristics(Watt,25°C)

F.V./TIME	5min	10min	15min	30min	60min	3h	5h	10h	20h
4.80V	80.4	51.9	44.6	24.6	15.3	5.76	4.12	2.28	1.20
5.10V	76.4	49.3	42.8	23.7	14.6	5.70	4.06	2.28	1.20
5.40V	72.0	46.4	40.6	22.5	13.9	5.58	4.00	2.22	1.20