

Dimensions

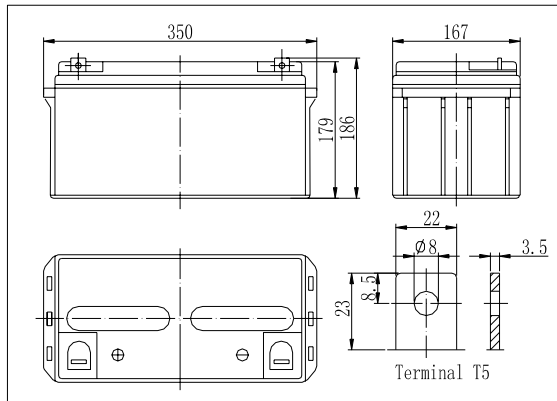

Specifications

Nominal Voltage	12 V	
Capacity(10HR, 25°C)	65 Ah	
Dimension	Length	350mm (13.78inch)
	Width	167mm (6.57inch)
	Height	179mm (7.05inch)
	Total Height	186mm (7.32inch)
Approx. Weight	22 kg (48.5lbs)	
Internal resistance (Fully charged, 25°C)	Approx.6m Ω	
Capacity affected by temperature (10HR)	40°C	102%
	25°C	100%
	0°C	85%
	-15°C	65%
Self-discharge (25°C)	3 month	Remaining Capacity: 91%
	6 month	Remaining Capacity: 82%
	12 month	Remaining Capacity: 65%
Nominal operating temperature	25°C ± 3°C (77°F ± 5°F)	
Operating temperature range	-15°C ~ 50°C (5°F ~ 122°F)	
Float charging voltage(25°C)	13.50 to 13.80V	
Cyclic charging voltage(25°C)	14.50 to 14.90V	
Maximum charging current	19.5A	
Terminal material	Copper	
Maximum discharge current	650A(5 sec.)	

- ◆ Absorbent glass mat technology;
- ◆ Recognized by UL & CE;
- ◆ ABS container.

Charging Characteristics(25°C)

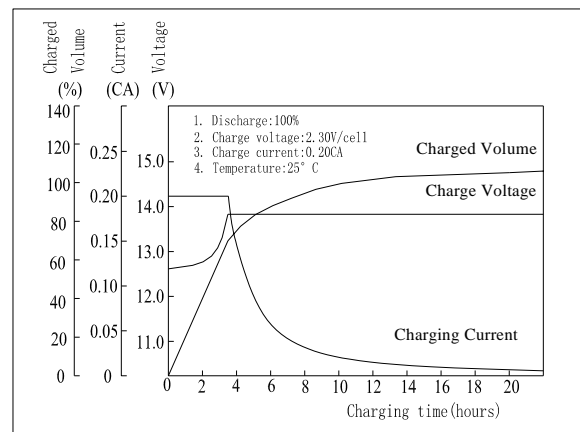

Cycle Life(25°C)

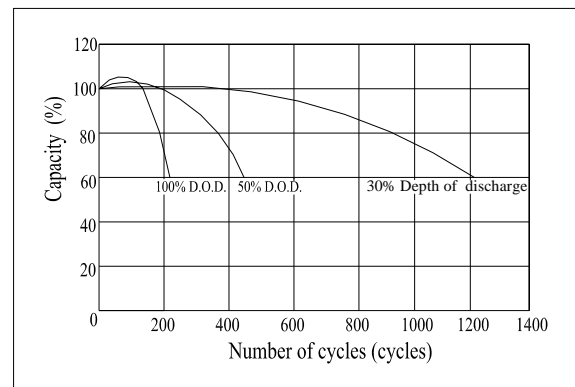

Note: Floating life at 20°C designed for 10 years.

Constant Current Discharge Characteristics (A, 25°C)

F.V/TIME	5min	10min	15min	30min	60min	3h	5h	10h	20h
9.60V	205	143	110	67.0	41.0	16.7	11.7	6.65	3.45
10.2V	195	136	106	64.3	39.4	16.5	11.5	6.60	3.45
10.8V	183	128	100	61.1	37.4	16.2	11.3	6.50	3.40

Constant Power Discharge Characteristics (Watt, 25°C)

F.V/TIME	5min	10min	15min	30min	60min	3h	5h	10h	20h
9.60V	2153	1544	1208	752	467	196	138	79.4	41.4
10.2V	2045	1467	1159	722	449	194	136	78.8	41.4
10.8V	1922	1379	1102	686	426	191	134	77.6	40.8